

GMM
STONE MACHINERY

TECHNOLOGY & INNOVATION

Intec510-G2[®] Intec713-G2[®]

HIGH-PRESSURE WATERJET SYSTEMS / SISTEMI A GETTO D'ACQUA AD ALTA PRESSIONE

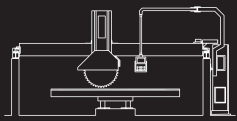

BRIDGE SAWING MACHINES
SEGATRICI A PONTE

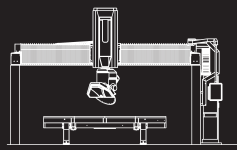

5-AXIS SAWING MACHINES
FRESE 5 ASSI

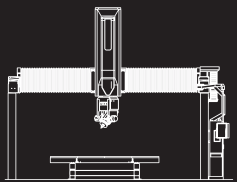

5-AXIS SHAPING MACHINES
SAGOMATRICI 5 ASSI

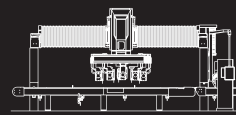

CUTTING CENTER MACHINES
CENTRI DI TAGLIO

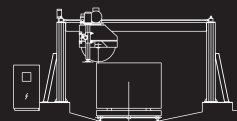

BLOCK CUTTER
TAGLIABLOCCHI



EDGE POLISHER / LUCIDACOSTE

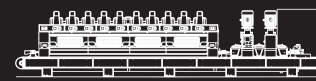

CALIBRATING AND POLISHING MACHINES
CALIBRATRICI-LUCIDATRICI

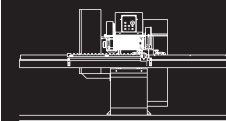

LINE ACCESSORIES
COMPLEMENTI DI LINEA

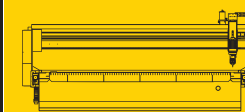

WATER JET

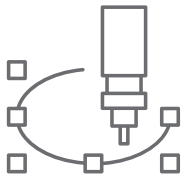

CNC
TECHNOLOGY

i713-G2





TECHNOLOGY & INNOVATION



EXPERIENCE & QUALITY



POWER & CONTROL

Intec510-G2®
Intec713-G2®



High-pressure waterjet systems

The Intec-G2® can cut almost any material to 8" thick at maximum cutting speed with minimum capital outlay. These machines last longer and require less maintenance, while delivering an easy to use, fast and accurate system at a very competitive price. This series of machines is particularly well-suited for stone industry.

- Softec™ Waterjet Cutting Software has been developed by TECHNI Waterjet™ with two very clear goals in mind:
 1. To cut parts at minimum cost with the greatest accuracy.
 2. To have a simple and intuitive interface with the operator.

The result is a comprehensive "All In One" Windows based software, that is specifically designed for Waterjet Cutting, which maximizes productivity and anyone with PC experience can learn to use quickly and easily.

At the "Heart" of Softec™ is Tru-Cut Technology™, a highly sophisticated algorithms database that determines the optimum cutting speeds and machine ramping characteristics. Once you select the material to be cut, it's thickness and surface edge finish required, the computer will take care of the rest, ensuring the minimum cutting time for any given part.

Programming edges for mitring within seconds. All with one software!

- Softec Nest utilizes advance nesting algorithms which have been developed by one of the world's largest and most awarded CAD and nesting software developers – Geometric Global. Benefits Include:
Improves profitability by minimising rapid feed times.
Increasing both nesting speed and material yield.



Sistemi a getto d'acqua ad alta pressione

Intec-G2® è in grado di tagliare quasi ogni tipo di materiale sino a 200 mm di spessore alla sua massima velocità di taglio, con la minor spesa possibile.

Le macchine della serie Intec G2 durano più a lungo e richiedono meno manutenzione grazie a un sistema facile da utilizzare, rapido e preciso. Questa gamma di macchine è particolarmente indicata per l'industria della pietra.

- Softec™, il software per il taglio a getto d'acqua, è stato sviluppato da TECHNI Waterjet™ con due obiettivi ben precisi:
 1. Riduzione dei costi di lavorazione garantendo la massima precisione.
 2. Avere un'interfaccia operatore semplice e intuitiva.

Il risultato è un software "All In One", in ambiente Windows, progettato appositamente per il Taglio a getto d'acqua in grado di aumentare la produttività e facile da usare.

"Cuore" del Softec™ è Tru-Cut Technology™, un database di algoritmi altamente sofisticato che determina le velocità di taglio ottimali e garantendo la realizzazione di spigoli perfetti sia verticali che inclinati. Dopo aver selezionato la tipologia del materiale da tagliare, lo spessore e la rugosità richiesta, il sistema elaborerà pressione, avanzamento, compensazione dell'inclinazione di Taglio per soddisfare le richieste dell'utente.

Riduce i tempi di lavoro, i costi di taglio, migliora la produttività, limita gli scarti e ottimizza i sistemi di gestione. Tutto attraverso il software!

- Softec Nest utilizza avanzati algoritmi di nesting elaborati da uno dei maggiori e più accreditati sviluppatori mondiali, la Geometric Global.

I vantaggi includono:

Migliore redditività, minimizzando i trasferimenti in sorvolo tra i tagli.

Aumentata velocità di nesting e migliore sfruttamento del materiale.



Sistemas de chorro de agua a alta presión

Intec-G2® es capaz de cortar casi cualquier tipo de material de hasta 200 mm de espesor en su máxima velocidad de corte, con el menor gasto.

Las máquinas de la serie Intec-G2® duran más y requieren mínimo mantenimiento gracias a un sistema rápido, preciso y fácil de usar. Esta gama de máquinas está particularmente indicada para la industria de la piedra.

- Softec™, el software de corte por chorro de agua, ha sido desarrollado por TECHNI Waterjet, con dos objetivos precisos:
 1. Reducción del coste de procesamiento que garantiza la máxima precisión.
 2. Tener una interfaz de operador simple e intuitiva.

El resultado es un software "todo en uno", en el entorno de Windows, diseñado específicamente para el corte por chorro de agua capaz de aumentar la productividad y fácil de usar.

"Heart" de Softec™ es Tru-Cut Technology™, una base de datos de algoritmos altamente sofisticados que determina las velocidades de corte óptimo y asegurando la creación de bordes perfectos, tanto vertical como inclinado. Después de seleccionar el tipo de material a cortar, el espesor y la rugosidad requerida, el sistema procesará presión, progreso, compensación e inclinación para cumplir con los requisitos del usuario.

Reduciendo el tiempo de trabajo, los costes y mejorando la productividad. Limita el desperdicio y optimiza los sistemas de gestión. Todo el software!

- Softec Nest utiliza algoritmos de anidación avanzados procesados por uno de los desarrolladores más grandes y acreditados del mundo, el Geometric Global.

Los beneficios incluyen:

Mejora de la rentabilidad, minimizando la transferencia de sobrevuelo entre cortes.

Aumento de la velocidad y mejor anidación.

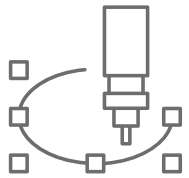
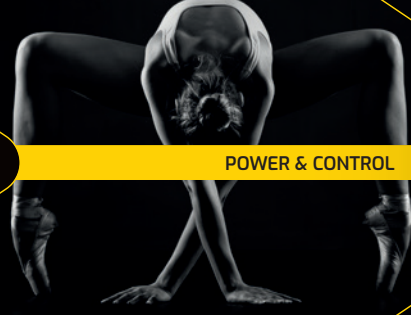

CNC
TECHNOLOGY



i510-G2

TECHNICAL DATA / DATI TECNICI

MODULE MODULO	i510-G2	i713-G2
MACHINE SIZE (L x W x H) Does not include pumps or control cabinet <i>DIMENSIONI MACCHINA (LUNG x LARG x H)</i> <i>Pompe o quadro comandi esclusi</i>	4200 x 2350 x 2050 mm 165" x 92" x 80"	5800 x 3100 x 2100 mm 228" x 122" x 82,5"
MACHINE WEIGHT <i>PESO MACCHINA</i>	2010 kg - 4431 lb	5720 kg - 12600 lb
MACHINE WEIGHT (with water) <i>PESO MACCHINA (con acqua)</i>	6800 kg - 15000 lb	13600 kg - 30000 lb
CUTTING TABLE DIMENSION <i>DIMENSIONI TAVOLA DI TAGLIO</i>	1550 x 3125 mm 61" x 123"	2000 x 4000 mm 78,7" x 157,5"
CUTTING AREA (without PAC 5 axis) <i>AREA DI TAGLIO (senza PAC 5 assi)</i>	1525 x 3050 mm 60" x 120"	2000 x 4000 mm 78,7" x 157,5"
BEVEL CUTTING AREA (with PAC 5 axis) <i>AREA DI TAGLIO INCLINATO (con PAC 5 assi)</i>	1160 x 2720 mm 45,6" x 107"	1640 x 3680 mm 64,5" x 144,8"
CUTTING AREA MAXIMIZED (with PAC 5 axis rotation) <i>AREA DI TAGLIO MASSIMIZZATA</i> <i>(con rotazione PAC 5 assi)</i>	1435 x 3005 mm 56,5" x 118"	1900 x 4000 mm 74,8" x 157,5"
ACCURACY OF MOTION <i>PRECISIONE DI MOVIMENTO</i>	0,15 mm/m	0,15 mm/m
REPEATABILITY OF MOTION <i>RIPETIBILITÀ DI POSIZIONAMENTO</i>	± 0,05 mm	± 0,05 mm
MAX. AIR SPEED <i>VELOCITÀ MAX MOVIMENTO RAPIDI</i>	17,5 m/min - 700 in/min	17,5 m/min - 700 in/min
MAX. CUTTING SPEED <i>VELOCITÀ MASSIMA DI TAGLIO</i>	17,5 m/min - 700 in/min	17,5 m/min - 700 in/min
MAX. MATERIAL THICKNESS <i>SPESSORE MASSIMO LAVORABILE</i> (with PAC60 cutting head option fitted) <i>(con testa PAC60)</i>	200 mm - 8" (115 mm - 4,5")	200 mm - 8" (115 mm - 4,5")

IMPORTANT NOTICE: Due to a constant endeavour to improve the machine, the specifications may change without prior notice. All the above accuracy tolerances are correct at the calibration temperature of 20° ± 1° C.

IMPORTANTE: i dati della presente tabella non sono impegnativi perchè soggetti a possibili variazioni senza preavviso per aggiornamenti e continue evoluzioni tecnologiche. Le tolleranze indicate sono corrette a una temperatura di calibrazione di 20° ± 1° C.



NEST™
ADVANCED NESTING SOFTWARE

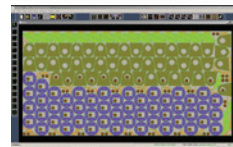
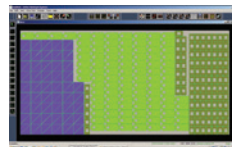

TECHNOLOGY & INNOVATION



EXPERIENCE & QUALITY



POWER & CONTROL

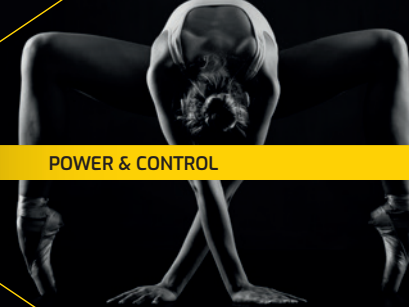

Intec510-G2®
Intec713-G2®

i510-G2

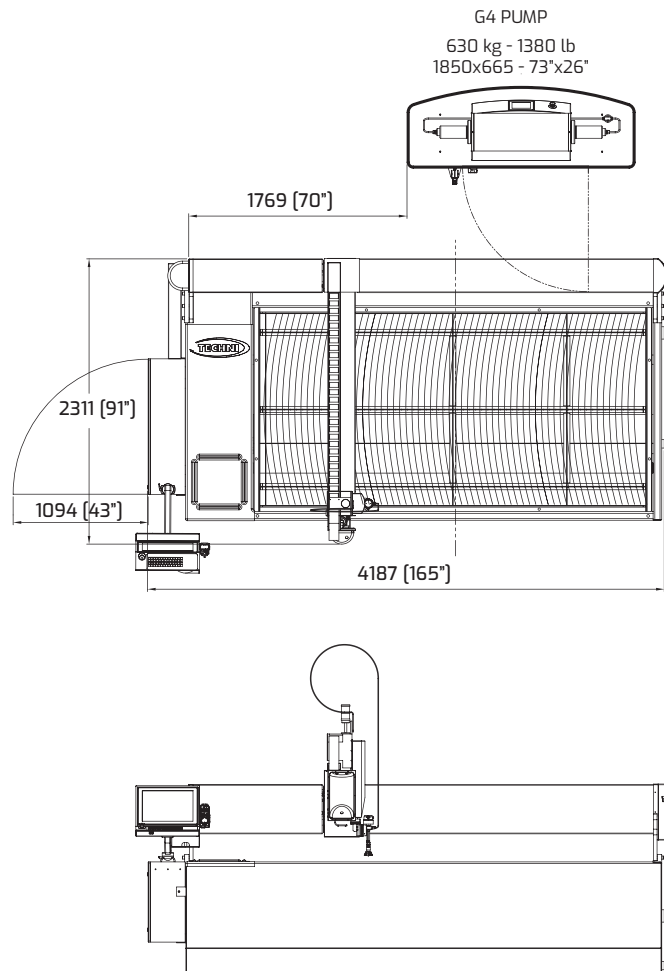

i713-G2

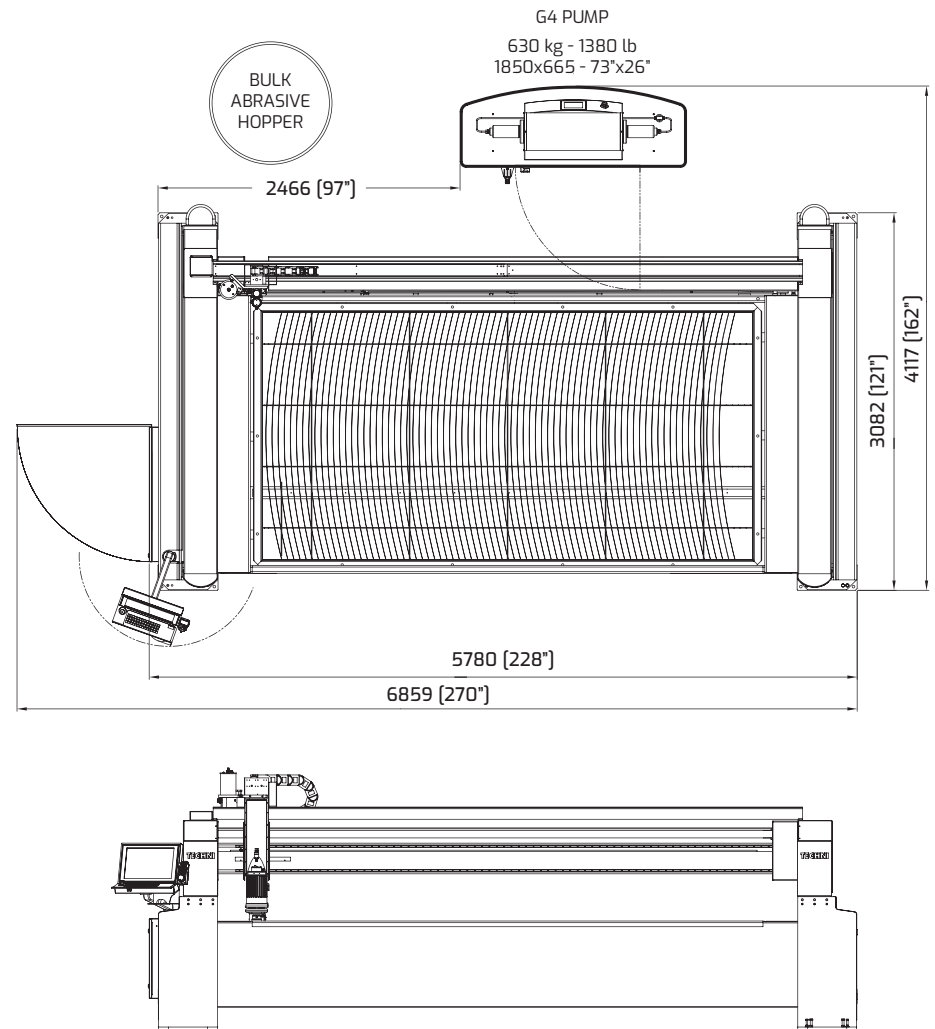



PAC60

- Cutting parts with a true angle up to +/- 60 degrees with continuous rotation.
 - Patented Kinematics to reduce cutting time significantly.
 - Complex 5-Axis Programming made easy and quick to learn.
 - Surface Scanner to maintain constant distance between nozzle and workpiece when cutting uneven slabs.
 - Positioning accuracy to ± 0.1 degrees.
 - Multi-pass cutting for edges with different angle.
 - Taper cutting automatic compensation.
-
- Taglio inclinato fino a 60° con rotazione continua senza riposizionamenti.
 - Cinematismo brevettato che riduce i tempi di taglio.
 - Programmazione semplificata di tagli complessi in 5 assi.



- Compensazione variazione spessore materiale sia per tagli verticali che inclinati.
- Tolleranza di posizionamento angolare +/- 0,1 gradi.
- Taglio multi-passata per realizzare bordi con angolazioni multiple.
- Compensazione automatica deviazione taglio.

ELECTRIC SERVO PUMP / SERVOPOMPA ELETTRICA

Quantum NXT™

The Quantum NXT™ pump is the smartest high-pressure water-jet cutting pump available in the market today, being up to 60% more energy efficient than hydraulic intensifiers.

Our advanced diagnostics brings Industry 4.0 to your workshop.

Quantum NXT™

La Quantum NXT™ è la pompa più efficiente presente sul mercato, che assicura una riduzione dell'assorbimento di corrente elettrica fino al 60%, silenziosità, facile manutenzione e sistema di controllo con diagnostica avanzata.



VP 15/52



ESP 37/66

G4 MODEL	VP 15/52	ESP 37/66
MAX OUTPUT PRESSURE PRESSIONE MASSIMA	3585 bar (52.000 psi)	4550 bar (66.000 psi)
MAX OUTPUT VOLUME* PORTATA MASSIMA*	1.9 l/min (0.5 gpm)	3.8 l/min (1.0 gpm)
PHYSICAL DIMENSIONS (L x W x H) DIMENSIONI (LUNG x LARG x H)	1300 x 540 x 1100 mm (51" x 21.25" x 42")	1800 x 660 x 1270 mm (73" x 26" x 50")
WEIGHT PESO	400 kg (881 lbs)	628 kg (1385 lbs)
MAX NOISE LEVEL IMPATTO ACUSTICO	68 dBA	70 dBA
POWER REQUIREMENTS* ALIMENTAZIONE ELETTRICA	3 PH 380-480 VAC, 50-60 Hz, 60 Amp (30 Amp for VP 15/52)	
COOLING WATER REQUIREMENT LIQUIDO DI RAFFREDDAMENTO	3 l/min (0.8 gpm) @ 20°C (68°F)	6 l/min (1.4 gpm) @ 20°C (68°F)
OPTIMAL COOLING WATER TEMP TEMP. OTTIMALE LIQUIDO DI RAFFR.	16°C (60°F)	12°C (54°F)

* Due to a constant endeavour to improve the machine, the specifications may change without prior notice.
* I dati del presente catalogo non sono impegnativi perché soggetti a possibili variazioni senza preavviso per aggiornamenti e continue evoluzioni tecnologiche.

* Output volume based on 480 vac electrical supply. * Portata massima basata su alimentazione 480 volt.

ADVANCED DIAGNOSTICS - Industry 4.0 ready
DIAGNOSTICA AVANZATA - Industry 4.0 ready

TEMPERATURE SENSORS SENSORI DI TEMPERATURA

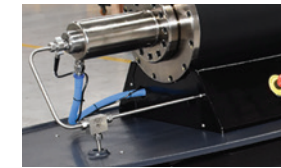

ALL DATA ON HAND
TUTTO SOTTO CONTROLLO

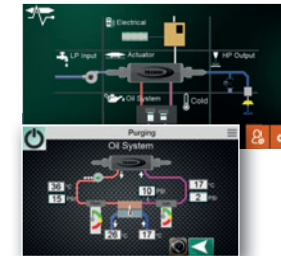

SERVICE COUNTERS
CONTATORI DI SERVIZIO



REMOTE ASSISTANCE
TELEASSISTENZA

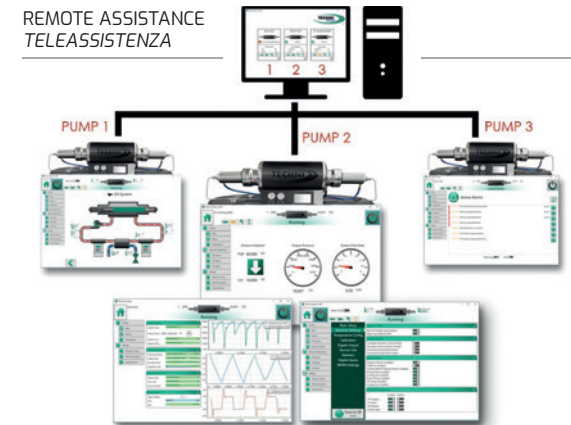

TECHNOLOGY & INNOVATION

EXPERIENCE & QUALITY

POWER & CONTROL

Intec510-G2®
Intec713-G2®

AMC5

AMC5 Servo Control System

TECHNI Waterjet's™ new control system, the AMC5, utilizes the very latest CNC and Digital Servo Drive system. Developed by our control system partner, ANCA, the world leader in CNC Tool and Cutter Grinders. The AMC5 has a Touch screen interface as well as a pointing mouse.

Sistema di servocontrollo AMC5

AMC5, il nuovo sistema di controllo TECHNI Waterjet's™ utilizza il CNC e il sistema di servoazionamento digitale più innovativo. Sviluppato da ANCA, nostro partner per i sistemi di controllo, leader mondiale nel settore degli utensili e delle rettificatrici CNC. L'AMC5 è dotato di un'interfaccia touch e di mouse.



ABRASIVE PUMP AND HOPPER ALIMENTATORE ABRASIVO



200 kg - OPTIONAL



2000 kg

TECH-SENSE



The patented Tech-Sense Monitoring System enables true unattended operations. This unique feature of Techni Waterjet provides the ability to run a night shift without the need for an attending operator. Should the cutting be disrupted, e.g. blocked nozzle, the machine will pause the program and send a text message to your cell phone.

Il sistema di monitoraggio brevettato TECH-SENSE consente lavorazioni di taglio non presidiate. Ciò permette all'operatore di allontanarsi dalla macchina mentre lavora per eseguire altre attività. Qualsiasi anomalia venga riscontrata la lavorazione si interrompe automaticamente e l'operatore riceve un messaggio sul suo cellulare.

BREAK AWAY HEAD SENSORE COLLISIONE UGELLO DI TAGLIO

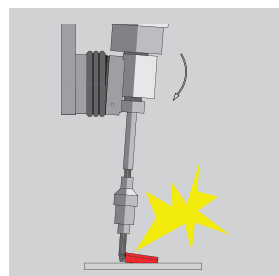

Not available when PAC60 installed.

Non disponibile quando è installata PAC60.

ABRASIVE REMOVAL SYSTEM SISTEMA DI ESTRAZIONE FANGO ABRASIVO



OPTIONAL

REMOTE CONTROL PENDANT PULSANTIERA PENSILE



The Remote Control Pendant makes setting up your waterjet machine fast, simple and accurate. The RCP gives the operator full jogging control in X-Y & Z, as well as along the programmed cut path. This function makes it ideal for finding the exact position to restart cutting if required for any reason.

La pulsantiera pensile permette una programmazione rapida, semplice e accurata della Vostra macchina a getto d'acqua. Dà all'operatore il completo controllo in modalità Jog degli assi X - Y e Z e esegue la simulazione di taglio in tempo reale. È la soluzione ideale per trovare la posizione esatta da cui far ripartire il taglio, qualora richiesto per una ragione qualsiasi.

Intec510-G2® | Intec713-G2® 06.2018

GMM

STONE MACHINERY



GMM S.P.A. HEADQUARTERS
 Via Nuova, 155 - 28883 Gravellona Toce (VB) ITALY
 Tel. +39 0323 849711 - Fax +39 0323 864517
gmm@gmm.it - www.gmm.it

GMM S.P.A. SCHIO BUSINESS UNIT
 Via Lago di Misurina 72
 236015 Schio (VI)
 ITALY
 Tel. +39 0445 576226
 Fax. +39 0445 576244
gmm@gmm.it
www.gmm.it

MECTOCE S.R.L. PRODUCTION UNIT
 Via Caduti del Lavoro 20/22
 28886 Pieve Vergonte (VB)
 ITALY
 Tel. +39 0324 86312
 Fax+39 0324 869677
informazioni@mectoce.it
www.mectoce.it

GMM INTERNATIONAL LTD.
 Unit 1717, New Tech Plaza, 34
 Tai Yau Street, Kowloon,
 HONG KONG
 Tel: +852-23666386
info@gmm.com.hk
www.gmmchina.cn

GMM (QUANZHOU) LTD.
 No.3C-1, Phase 2, Cathay Stone Mall,
 Shuitou Town, Nan'an City, Fujian Province,
 CHINA 362342
 Tel:+86 595 86097072
info@gmmchina.cn
www.gmmchina.cn

GMM USA INC.
 7606 Whitehall Executive
 Center Drive, Suite 400
 Charlotte,
 USA NC 28273
 Tel:+1 980-242-2969
Info.gmmusa@gmm.it
www.gmm.it

TECHNI WATERJET LTD.
MELBOURNE HEAD OFFICE
 47 Barry Rd,
 Campbellfield
 VICTORIA, AUSTRALIA 3061
 Tel. +61 3 9357 8360
 Fax +61 3 9357 0446
www.techniwaterjet.com

TECHNI WATERJET LTD.
THAILAND FACTORY
 300/21 MOO 1, Tambol Tasith
 vTel. +66 (0) 33 012 561-4
 Fax +66 (0) 33 012565
sales@techniwaterjet.com
www.techniwaterjet.com

Intec510-G2® | Intec713-G2®



WATERJET
 Intec613-G2®

Technical data are not binding and may be changed by GMM without prior notice.
 I dati tecnici non sono impegnativi e possono essere modificati da GMM senza preavviso.

ISO 9001
BUREAU VERITAS
 Certification



Member of
CONFINDUSTRIA MARMOMACCHINE
 ASSOMARMOMACCHINE



ISO 9001:2015 - Certificato N°IT234871

IMPORTANT: machines displayed in the present catalogue are without safety barriers in order to ensure the perfect vision of all the details of the machine. All machines will be delivered and installed with safety barriers as per current legislation. The data in the present catalogue may vary without notice due to continuous update of technology.

IMPORTANTE: alcune macchine sono sprovviste di alcune protezioni per meglio evidenziare le caratteristiche del prodotto. Alla consegna e alla installazione, tutte le macchine saranno munite delle protezioni secondo le vigenti norme di legge. I dati del presente depliant non sono impegnativi perché soggetti a possibili variazioni senza preavviso per aggiornamenti e continue evoluzioni tecnologiche.