

**GMM**  
STONE MACHINERY

POWER & CONTROL

# Extra 鷹創 400 CN2

MONOBLOCK CNC 5-AXIS SAWING MACHINE / 一体式数控五轴桥切机

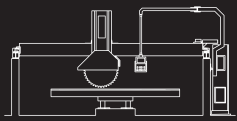

BRIDGE SAWING MACHINES

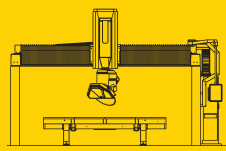

5-AXIS SAWING MACHINES  
五轴桥切机

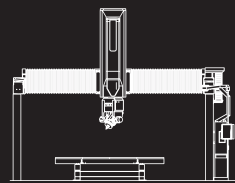

5-AXIS SHAPING MACHINES

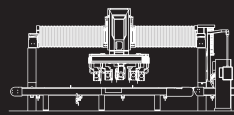

CUTTING CENTER MACHINES

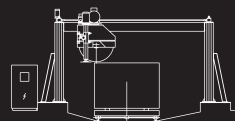

BLOCK CUTTER



EDGE POLISHER



CALIBRATING AND POLISHING MACHINES

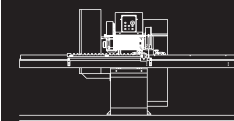

LINES AND  
COMPLEMENTARY MACHINERY

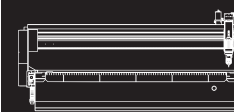

WATER JET

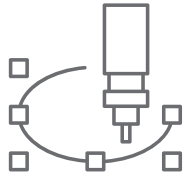

**CNC数控**  
TECHNOLOGY 技术



YouTube



意美美  
GmmChina





The machine combines extreme ease of use and intuitive programming of both basic operations than of the more advanced ones, such as offline programming, cad cuts, contouring, profiles and shapes, drilling, coring, bas-reliefs and lettering etc.

- 370° rotating head, 90° tilting head.
- Hydraulic tilting table driven by two hydraulic cylinders with dedicated hydraulic power unit, structure in hot-dip galvanized steel with PVC cover.
- Blade up to 625 mm (25 inches) diameter driven by inverter. Possibility to work with a minimum 300 mm (12 inch) disc.
- Vertical stroke (Z axis) of 400 mm (16 inch).
- All the main structures of the machine are in hot galvanized steel.
- Automatic lubrication. (NEW).
- Safety barriers with polycarbonate panels. (NEW).
- High speed, maximum precision thanks to brushless motors with absolute encoders, recirculating ball guides, helical cut rack and pinion (on request) and precision gearboxes, interpolation of the axes with CNC.
- 4,500 rpm electrospindle (6,000 rpm on request with shaft drilled for water passage and 36x2 - 1/2 "gas cutters).
- Vacuum system with 3 sections (on request). (NEW).
- Four position magnetic tool changer for auto changing core bits or router tools (on request).

鹰创併合了简易、直观、高效的操作系统，以达到轻松为石材进行加工。鹰创能根据CAD绘图进行各类加工，在切割、塑形、鑽孔、取芯、浮雕和刻字方面都有超卓表现，更支援离线工作。

- 370°旋转及90°倾斜的工作头
- 液压翻板台由2个液压缸驱动，配备转用液压动力装置，热镀锌钢结构，PVC台面
- 锯片最大支援直径 625毫米 (25吋)，由变频驱动，可以使用最少 300 毫米 (12 英寸) 的锯片。
- 垂直升降移动(Z轴)：400毫米 (16吋)
- 机器的所有主要结构为经过热镀锌处理的钢材
- 自动润滑功能 (新增)
- 折叠保护屏障，采用聚碳酸酯面板 (新增)
- 极高精度且高速的运作，有赖于CNC 数控智能对带有绝对编码器的无刷电机、循环球轴承、螺旋齿轮组(应要求提供)和精密齿轮箱等各个部件进行完美的联动操控
- 4500rpm 主轴 (应要求提供6000rpm主轴、配置中央出水及36x2 - 1/2 寸 GAS刀具)
- 3 区域真空吸盘 (应要求提供) (新增)
- 4位磁力刀具库，自动更换钻头或铣刀工具 (应要求提供)



TECHNICAL DATA / 技术参数

CUTTING STROKE OF THE BLADE (X AXIS) 切割行程 (X 轴)	3700 mm
MAXIMUM BRIDGE TRASLATION (Y AXIS) 最大桥身横移行程 (Y轴)	2700 mm
MAXIMUM VERTICAL TRAVEL OF THE BLADE (Z AXIS) 最大垂直行程 (Z 轴)	400 mm
BEVEL CUTTING AREA AT 45° (BLADE 400) 45° 斜角切割区域 (锯片400)	3400x2400 mm
MAX ANGLE OF TILT HEAD (R AXIS) 工作头最大倾斜角 (R 轴)	0°+90°
MAXIMUM BLADE ROTATION (W AXIS) 最大旋转角度 (W轴)	0°+370°
MINIMUM-MAXIMUM BLADE DIAMETER 最小/最大锯片直径	300-625 mm
MAXIMUM CUTTING DEPTH 最大切割深度	205 mm
BLADE HOLE DIAMETER 锯片中心孔直径	50/60 mm
BLADE LOCKING FLANGE DIAMETER 锯片固定法兰直径	213 mm
TABLE DIMENSION 工作台尺寸	2250-2400* x 3800 mm
BLADE MOTOR POWER 锯片马达功率	13 (56) kW
BLADE SPEED 锯片转速	800+4500-6000* rpm
SLIDE CUT SPEED (X AXIS) 工作头滑切速度 (X 轴)	0+35 m/min
BRIDGE TRANSLATION SPEED (Y AXIS) 桥移速度 (Y轴)	0+35 m/min
VERTICAL MOVEMENT SPEED (Z AXIS) 垂直移动速度 (Z轴)	0+7,5 m/min
WATER CONSUMPTION AT 3 BAR 水压耗量3巴	40 l/min
TOTAL MACHINE MASS 设备总重	4200 kg
MACHINE PACKING DIMENSIONS 装运规格	20' O.T. container 开顶柜

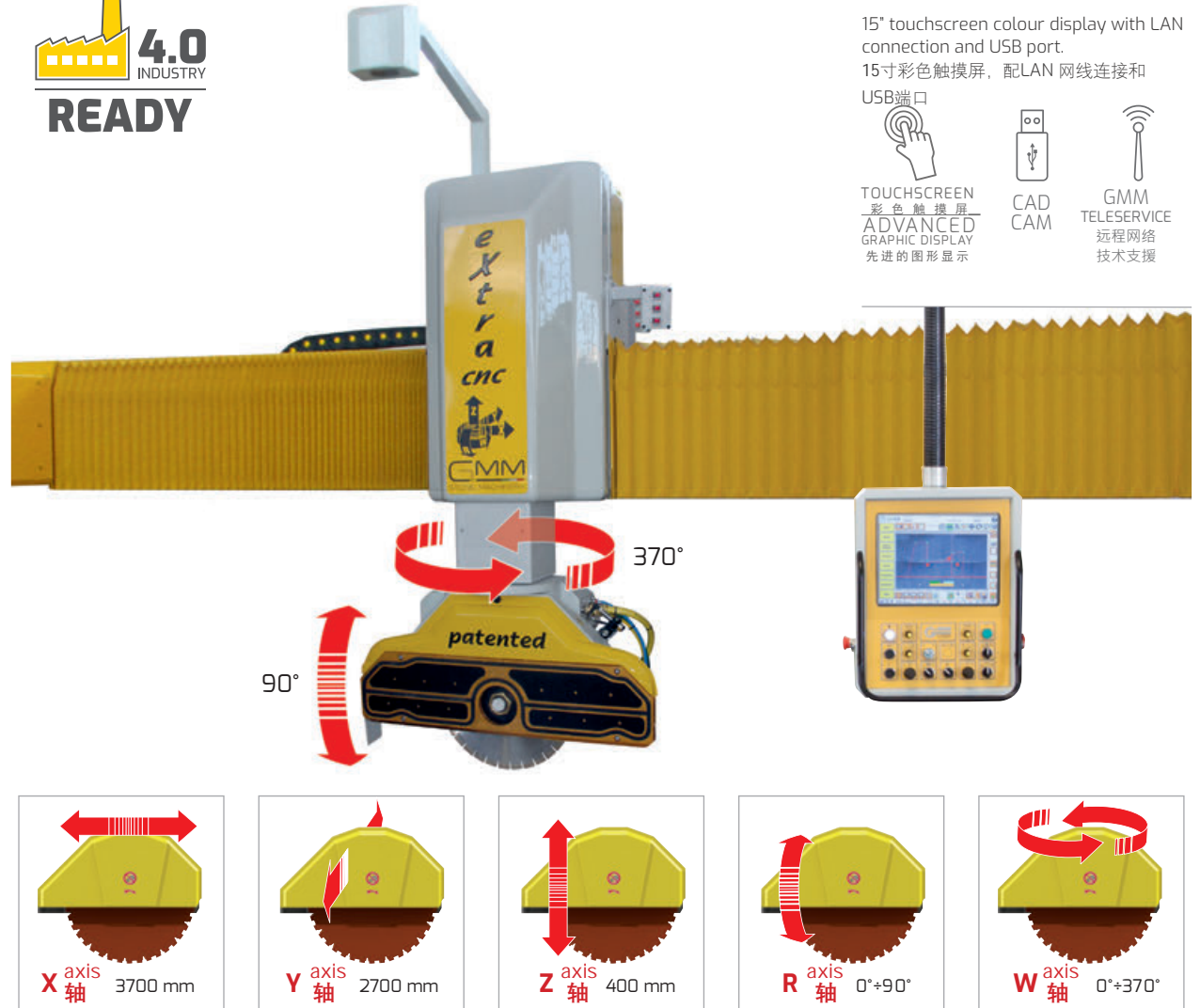

TECHNOLOGY & INNOVATION



EXPERIENCE & QUALITY



POWER & CONTROL

Extra 鹰创 400 CN2

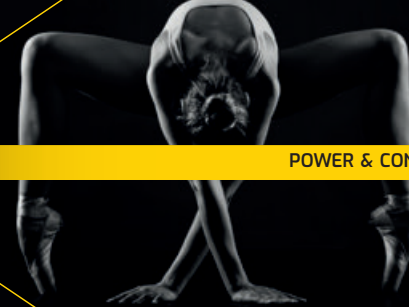

### STANDARD MACHINE PROGRAM / 机械标准程序

CODE 编号 : MF 156



Single cut, multiple cuts, inclined or mitre cuts.  
单次切 · 多次切 · 倾斜切

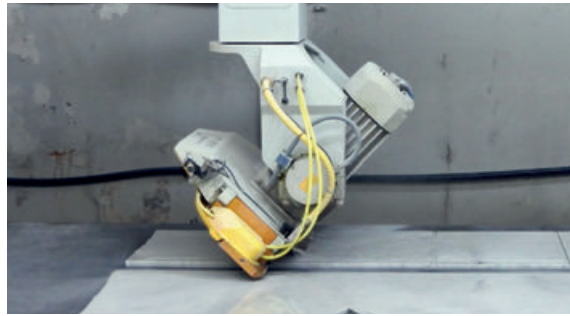

Orthogonal cuts and polygons.  
正交及多边形切割

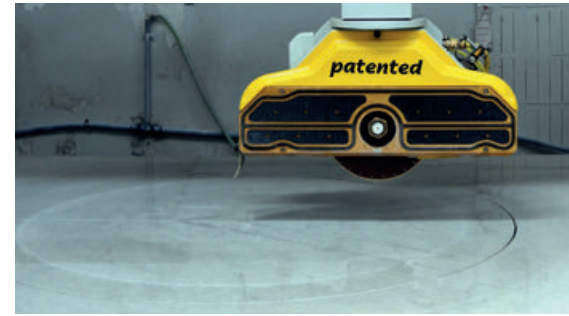

Circumferences, archs. 切圆 · 弧线

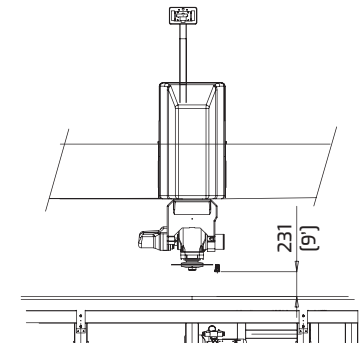
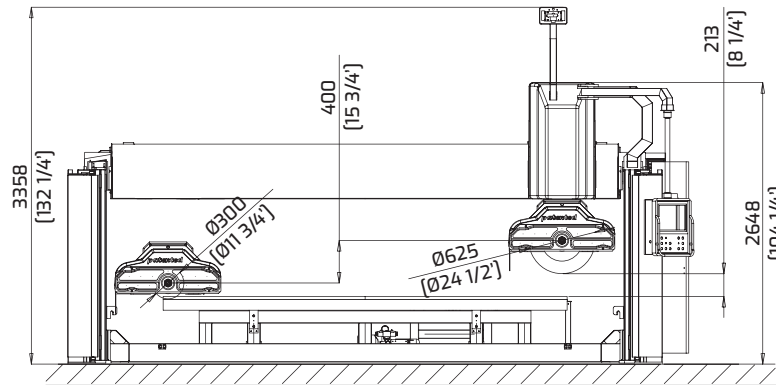
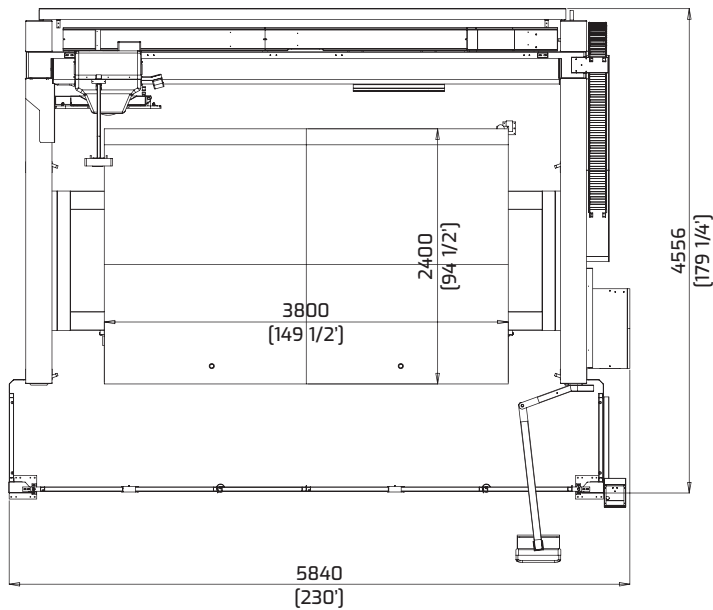



POWER & CONTROL



EXPERIENCE & QUALITY



TECHNOLOGY & INNOVATION

OPTIONAL ON REQUEST / 选项

CODE 编号: A1259

VACUUM BLADE GUARD WITH COOLING TOOL NOZZELS

带冷却工具喷嘴的真空锯片防护罩

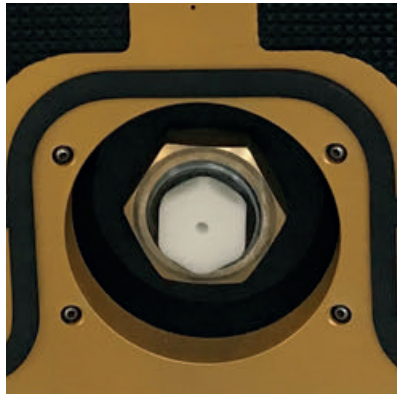

CODE 编号: A1712

TWO POSITION MAGNETIC TOOL CHANGER FOR AUTO CHANGING CORE BITS

2 位磁力刀具库 · 用于自动更换钻头或铣刀工具

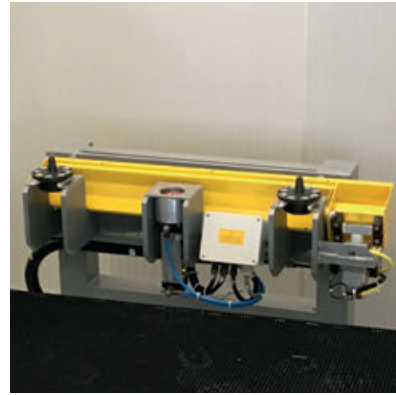

CODE 编号: A1718

FOUR POSITION MAGNETIC TOOL CHANGER FOR AUTO CHANGING CORE BITS OR ROUTER TOOLS

4 位磁力刀具库 · 用于自动更换钻头或铣刀工具



CODE 编号: A5501

TOOL DIAMETER CONTROL

刀具直径或长度测量器



CODE 编号: A5504

SLAB THICKNESS READER

大板厚度检测仪

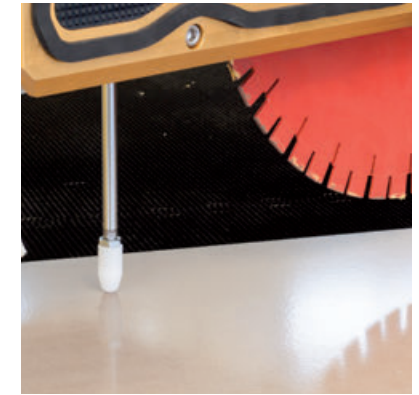

CODE 编号: A5453

CAMERA ON BOARD

摄像头



CODE 编号: A6423

OPTICAL TEMPLATE COPIER

光学模板探测器

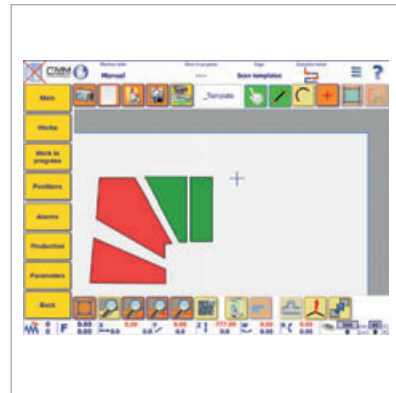

CODE 编号: A6450

PARAMETRIC PROGRAM

参数化设计程序

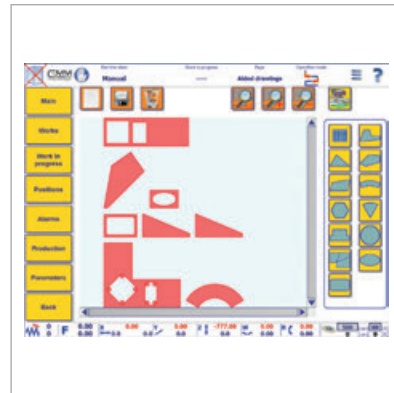

CODE 编号: A6457

PROGRAM COMBINED CUTS FROM CAD

CAD 组合切割程序

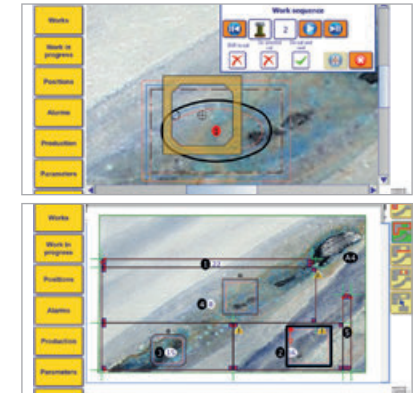

CODE 编号: A2646

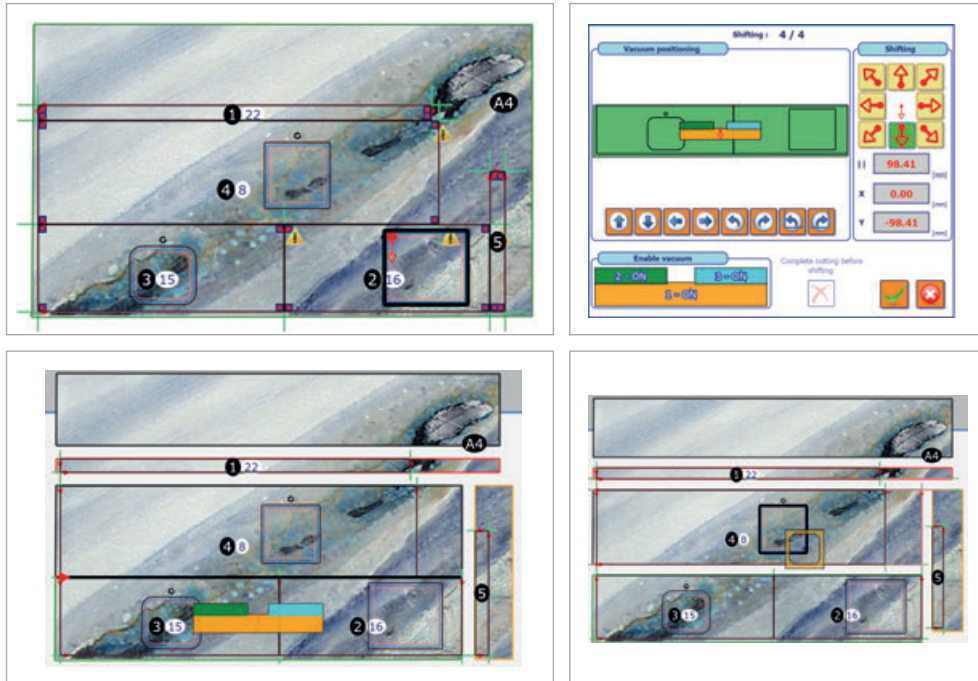
Vacuum system  
真空吸盘

Vacuum system with 3 sections, disc casing of  $\varnothing 625$  mm instead of the standard one and related software.  
The vacuum head blade cover is made with a special alloy of cast aluminum, corrosion resistant, reinforced and ribbed.

吸盘的三个区域置于锯片罩表面·  
锯片罩最大可装 $\varnothing 625$ mm的锯片·  
吸盘罩由特制铸造铝合金制成·防锈功能强·

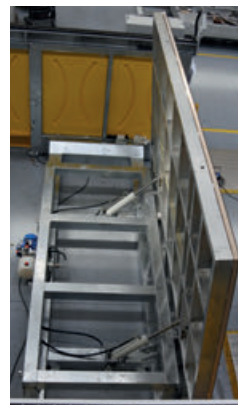
Hydraulic tilting table  
液压翻板台

Hydraulic tilting table driven by two hydraulic cylinders with dedicated hydraulic power unit, structure in hot-dip galvanized steel with PVC cover.

液压翻板台由2个液压缸驱动·配备转用液压动力装置·热镀锌钢结构·PVC台面



GMM S.P.A.  
**HEADQUARTER 意大利总部**  
 Via Nuova, 155 - 28883 Gravelona Toce (VB) ITALY  
 Tel. +39 0323 849711 - Fax +39 0323 864517  
 gmm@gmm.it - www.gmm.it

GMM S.P.A. SCHIO  
**BUSINESS UNIT**  
 Via Lago di Misurina, 72 - 36015 Schio (VI) IT ALY  
 Tel. +39 0445 576226 - Fax +39 0445 576244  
 gmm@gmm.it - www.gmm.it

MECTOCE S.R.L.  
**PRODUCTION UNIT**  
 Via Caduti del Lav oro, 20/22 - 28886 Pieve Vergonte (VB) IT ALY  
 Tel. +39 0324 86312 - Fax +39 0324 869677  
 informazioni@mectoce.it - www .mectoce.it

GMM STEINBEARBEITUNGSMASCHINEN GMBH  
**COMMERCIAL / AFTER SALES UNIT**  
 Karlshöhlchen 6  
 76872 Freckenfeld  
 GERMANY  
 Tel. +49 6340 7119652  
 info@gmm-steinbearbeitung.de  
 www.gmm-steinbearbeitung.de

WPA WATERJET PRODUCTION ACADEMY GMBH  
**DISTRIBUTOR**  
 Zeppelinstraße 7a  
 76185 Karlsruhe  
 GERMANY  
 Tel. +49(0)721 46466226  
 info@wpa-gmbh.com  
 www.wpa-gmbh.com

GMM USA INC.  
**COMMERCIAL / AFTER SALES UNIT**  
 8610 Airpark West Drive  
 Suite 100  
 Charlotte, NC 28214  
 USA  
 Tel. +1 980 242 2969  
 info.gmmusa@gmm.it  
 www.gmm.it

TECHNI WATERJET LLC  
**COMMERCIAL / AFTER SALES UNIT**  
 8610 Airpark West Drive  
 Suite 100  
 Charlotte, NC 28214  
 USA  
 Tel. +1 980 242 2969  
 enquiry@techniwaterjet.com  
 www.techniwaterjet.com

TECHNI WATERJET LTD.  
**PRODUCTION UNIT**  
 300/21 MOO 1, Tambol Tasith  
 Ampur Pluakdaeng, R ayong,  
 THAILAND 21140  
 Tel. +66 (0) 33 012 561-4  
 Fax +66 (0) 33 012 565  
 sales@techniwaterjet.com  
 www.techniwaterjet.com

TECHNI WATERJET LTD.  
**MELBOURNE HEAD OF FICE**  
 47 Barry Rd.  
 Campbellfield - VIC ORIA  
 AUSTRALIA 3061  
 Tel. +61 3 9357 8360  
 Fax +61 3 9357 0446  
 www.techniwaterjet.com

GMM INTERNATIONAL LTD.  
 凌意国际有限公司  
 Unit 1717, New Tech Plaza,  
 34 Tai Yau Street, Kowloon  
 HONG KONG  
 香港九龙大有街34号  
 新科技广场17楼17室  
 Tel: +852-23666386  
 Fax:+852-23670525  
 info@gmm.com.hk  
 www.gmmchina.cn

GMM (QUANZHOU) LTD.  
 泉州意美美机械有限公司  
 No.3C-1, Phase 2, Cathay Stone Mall,  
 Shuitou Town, Nan'an City, Fujian Pro vince,  
 CHINA 362342  
 福建南安市海联创业园海西石材城大理石  
 精品市场二期分区商铺3C-1 邮编:362342  
 Tel: +86-595-86097072  
 +86-13430504901  
 info@gmmchina.cn  
 www.gmmchina.cn

## Extra 鷹創 400 CN2

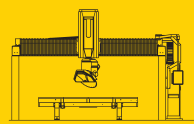

### 5-AXIS SAWING MACHINES / 五轴桥切机

Brio Easy 400 CN2 | Intra 520 CN2 | Intra 520 XL CN2 | Egil 700 CN2

Technical data are not binding and may be changed by GMM without prior notice.  
 技术参数不具有约束力 · GMM可能会更改 · 恕不另行通知 ·

**IMPORTANT:** machines displayed in the present catalogue are without safety barriers in order to ensure the perfect vision of all the details of the machine. All machines will be delivered and installed with safety barriers as per current legislation. The data in the present catalogue may vary without notice due to continuous update of technology.

**重要说明:** 本说明书为了更清晰地展现设备全貌, 在拍照时撤离了安全保护屏障, 设备在实际交付与安装时都会配备安装保护屏。本产品说明书中的所有参数可能因更新原因而有所不同, 请按照当时咨询时为准。