

GMM
STONE MACHINERY

EXPERIENCE & QUALITY

优锐

Eura 35 TS3

AUTOMATIC ELECTRONIC BRIDGE SAWING MACHINE

自动电子桥式切割机



BRIDGE SAWING MACHINES
桥式切割机

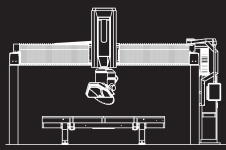

5-AXIS SAWING MACHINES

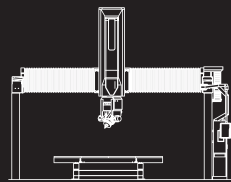

5-AXIS SHAPING MACHINES

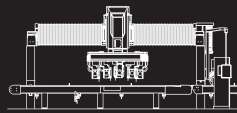

CUTTING CENTER MACHINES

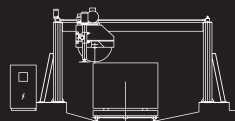

BLOCK CUTTER

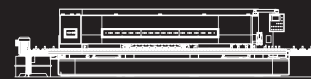

EDGE POLISHER



CALIBRATING AND POLISHING MACHINES

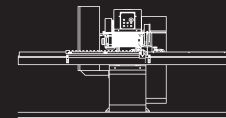

LINE ACCESSORIES

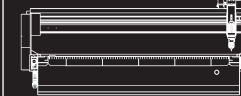

WATER JET



POWER & CONTROL



EXPERIENCE & QUALITY



TECHNOLOGY & INNOVATION



YouTube



意美美
GmmChina





TECHNOLOGY & INNOVATION



EXPERIENCE & QUALITY



POWER & CONTROL

Eura 优锐 35 TS3

Basic machine for all workshops: it may be fitted with blades, suitable for both marble and granite, and may be operated manually or automatically.

- *Max blade size of 625 mm (24.6 in).*
- *Main structures made of cast iron and stainless steel protections.*
- *The basic version of this machine will be supplied complete of:*
 - *tilting head from 0° to 60° for marble and granite;*
 - *blade inverter;*
 - *optical collimator;*
 - *manual rotating table with blocking device from 0° to 360° (automatic - optional);*
 - *multiple cutting program with colour display 12" Touch Screen;*
 - *profile copier (optional);*
 - *CE - ETL norms;*
 - *folding door solid panel safety barrier.*

配置相应的锯片，适合切大理石和花岗石，可进行手动或自动。
。横梁为一体铸铁。何谓一体：中间的主梁不是用螺栓与左右横梁座连接，而是整体铸造成形。

- 最大锯片直径 625毫米 (24.6 吋)
- 主要结构采用铸铁制造和不锈钢防护
- 机器基本版提供完整：
 - 手动 0° - 60° 倾斜头
 - 主马达变频器
 - 红外线仪
 - 手动旋转工作台 0° - 360° (可选项：自动旋转工作台)
 - 程序设定多次切割，12 吋彩色触摸屏
 - 仿形复制器 (选项)
 - 欧盟标准
 - 折叠门式的保护屏障

TECHNICAL DATA 技术参数

71 HHB; GHFC79C; H: 96@589 fL 5L-GE 切割行程 (X轴)	3500 mm
A 5L-A I A 6F-8; 9HF5BG@5HC B 1M5L-GE 最大桥身横移行程 (Y轴)	3500 mm
A 5L-A I A 1 J 9FH75@HF 5J 9@C: H: 96@589 fN 5L-GE 最大垂直行程 fN 上	320 mm
A 5L-A I A 5B; @9C: H@H< 958 fF 5L-GE 工作台最大倾斜角 fF 上	60°
A 5L-A I A 1 J 9FH75@6@5898-5A 9H9F 最大	625 mm
6@589<C@98-5A 9H9F 锯片中心孔直径	50 mm
6@589@7?@B; : @5B; 98-5A 9H9F	213 mm
A 5L-A I A 71 HHB; 89DH< 最大切割深度	205 mm
: 4.98 H56@98-A 9BG-C B 工作台尺寸	1500 x 3000 mm
DCK 9F C: H: 96@589 A CHCF 锯片马达功率	16.5 (5.6) kW
GD-B8@9GD998 C: FCH5HC B	900 - 4300 rpm
G@8971 HGD998 fL 5L-GE 工作台滑切速度 (X轴)	0 - 18 m/min
K 5H9F 7CBGI A DHCB 5H 6 65F 水压耗量3巴时	40 l/min
5F 7CBGI A DHCB 5H 6 65F 气压耗量6巴时	5 l/min
HCH5@A 57<-B9A 5GG	3400 kg
A 57<-B9D57?@B; 8-A 9BG-C BG	20' O.T. container

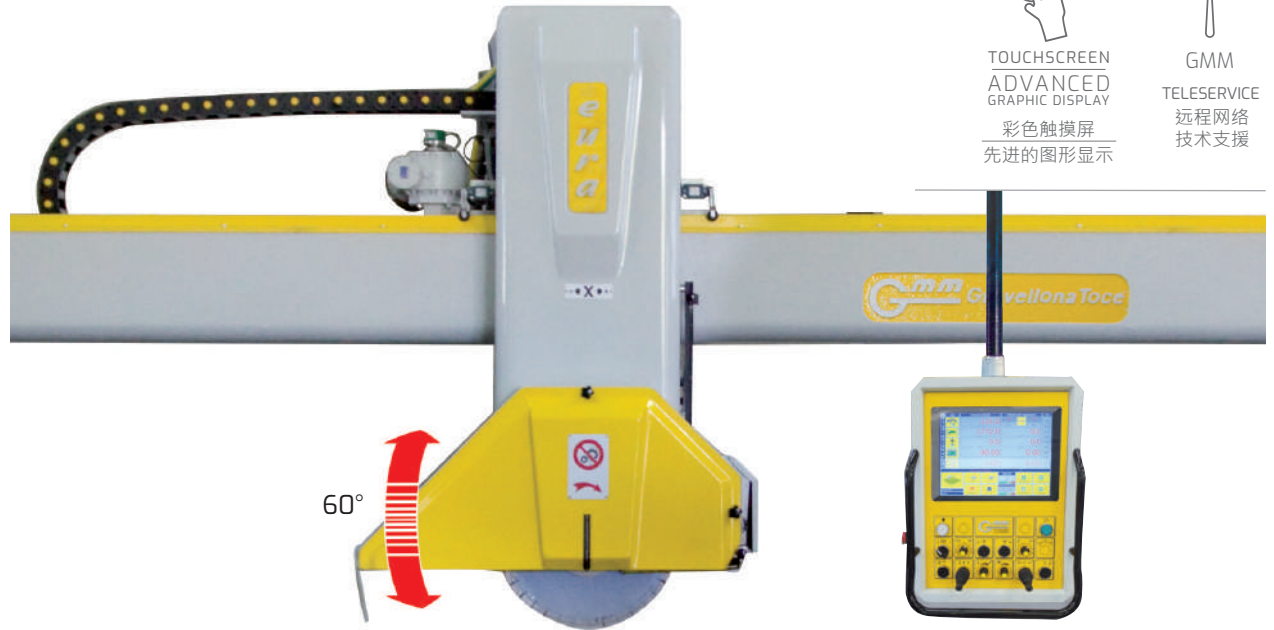

TOUCHSCREEN
ADVANCED
GRAPHIC DISPLAY
彩色触摸屏
先进的图形显示

GMM
TELESERVICE
远程网络
技术支持

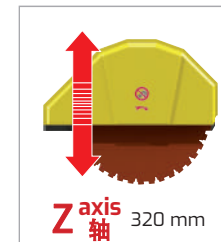
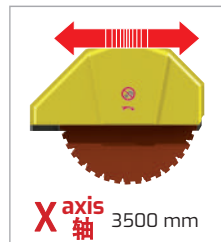

PROGRAMMING AND CONTROL UNIT

程序和控制单元

92" hci VxgWYYb V@ci f X]gd Umk]h @5B V@bbYV]cb UbX I G6'dcff"
92" 彩色触摸屏 · 配LAN网线连接和USB端口

TECHNOLOGY & INNOVATION



EXPERIENCE & QUALITY



POWER & CONTROL



Eura 优锐 35 TS3

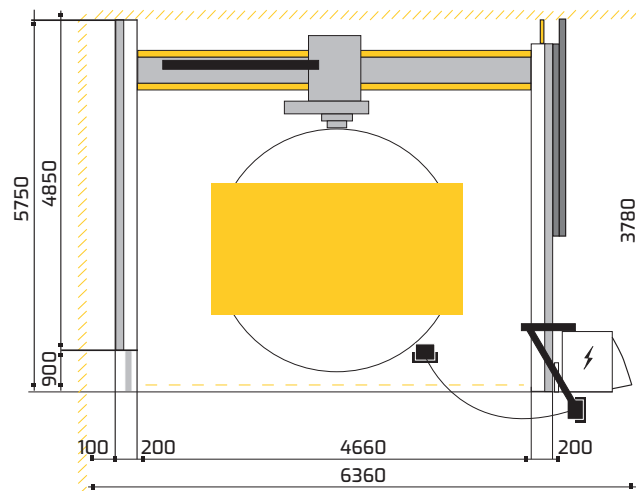

CODE: MF561 STANDARD MACHINE PROGRAM

编号: MF561 机械标准程序



Single cut , multiple cuts
单次切 · 多次切



Inclined cuts
倾斜切

OPTIONS 选项

CODE 编号: A6431
PROFILES & SHAPES
仿形功能

CODE 编号: A2118
HYDRAULIC TILTING TABLE
液压翻板台

CODE 编号: A2225
MOTORIZED
PROGRAMMABLE ROTATING TABLE
(CUST IRON)
可编程电动旋转台 0° - 360° (铸铁)

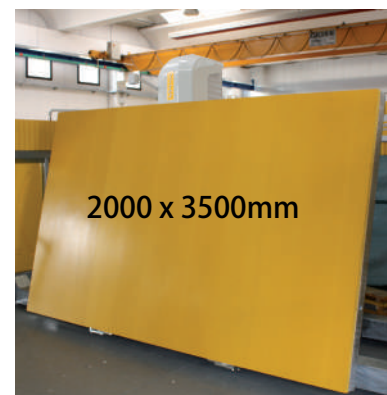
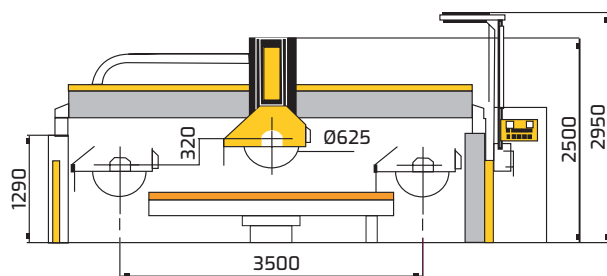

Eura 35 TS3 10. 2018

GMM
STONE MACHINERY



GMM S.P.A. HEADQUARTERS
意大利总部

Via Nuova, 155 - 28883 Gravellona Toce (VB) ITALY
Tel: +39-0323-849711 ; Fax: +39-0323-864517
gmm@gmm.it ; www.gmm.it

GMM S.P.A. SCHIO
BUSINESS UNIT
Via Lago di Misurina 72
36015 Schio (VI) ITALY
Tel: +39-0445-576226
Fax: +39-0445-576244
gmm@gmm.it
www.gmm.it

MECTOCE S.R.L.
PRODUCTION UNIT
Via Caduti del Lavoro
20/22 28886
Pieve Vergonte (VB)
ITALY
Tel: +39-0324-86312
Fax: +39-0324-869677
informazioni@mectoce.it
www.mectoce.it

GMM INTERNATIONAL LTD.
凌意国际有限公司
Unit 17, 17th Floor,
New Tech Plaza,
34 Tai Yau Street, Kowloon,
HONG KONG
香港九龙大有街34号
新科技广场17楼17室
Tel: +852-23666386
Fax: +852-23670525
info@gmm.com.hk
www.gmmchina.cn

GMM (QUANZHOU) LTD.
泉州意美美机械有限公司
No.3C-1, Phase 2, Cathay Stone Mall,
Shuitou Town, Nan'an City,
Fujian Province, CHINA 362342
福建南安市海联创业园海西石材城大理石
精品市场二期分区商铺3C-1 邮编:362342
Tel: +86-595-86097072
+86-18659013649
info@gmmchina.cn
www.gmmchina.cn

GMM USA INC.
COMMERCIAL /
AFTER SALES UNIT
8610 Airpark West
Drive, Suite 100,
Charlotte
USA NC 28214
Tel: +1-980-242-2969
info.gmmusa@gmm.it
www.gmm.it

TECHNI WATERJET LTD.
MELBOURNE
HEAD OFFICE
47 Barry Rd,
Campbellfield
VICTORIA,
AUSTRALIA 3061
Tel: +61-3-9357-8360
Fax: +61-3-9357-0446
www.techniwaterjet.com

TECHNI WATERJET LTD.
PRODUCTION UNIT
300/21 MOO 1,
Tambol Tasith Ampur
Pluakdaeng, Rayong,
THAILAND 21140
Tel: +66-033-012561-4
Fax: +66-033-012565
sales@techniwaterjet.com
www.techniwaterjet.com

TECHNI WATERJET LLC
COMMERCIAL /
AFTER SALES UNIT
8610 Airpark West
Drive, Suite 100,
Charlotte
USA NC 28214
Tel: +1-980-242-2969
enquiry@techniwaterjet.com
www.techniwaterjet.com

Eura 优锐 35 TS3



BRIDGE SAWING MACHINES 桥式切割机
Tecna 36 TS3 | Axia 38 TS3 | Radia 38 TS3 | Diama 40 TS3

Technical data are not binding and may be changed by GMM without prior notice.
技术参数不具有约束力 · GMM可能会更改 · 恕不另行通知。



ISO 9001:2015 - Certificato N°IT234871

IMPORTANT: machines displayed in the present catalogue are without safety barriers in order to ensure the perfect vision of all the details of the machine. All machines will be delivered and installed with safety barriers as per current legislation. The data in the present catalogue may vary without notice due to continuous update of technology.

重要说明: 本说明书为了更清晰地展现设备全貌, 在拍照时撤除了安全保护屏障, 设备在实际交付与安装时都会配备安装保护屏。本产品说明书中的所有参数可能因更新原因而有所不同, 请按照当时咨询时为准。