

GMM
STONE MACHINERY

POWER & CONTROL

DEVERO CNC

GANTRY MANIPULATOR 智能卸载机械手

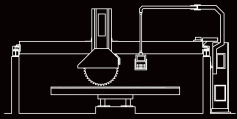

BRIDGE SAWING MACHINES

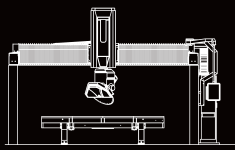

5-AXIS SAWING MACHINES

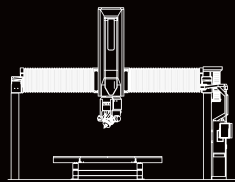

5-AXIS SHAPING MACHINES

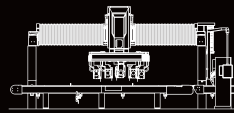

CUTTING CENTER MACHINES

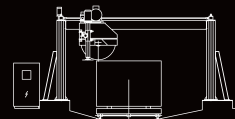

BLOCK CUTTER



EDGE POLISHER

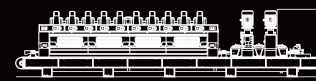

CALIBRATING AND POLISHING MACHINES

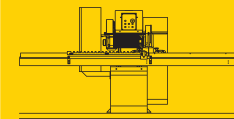

LINES AND
COMPLEMENTARY MACHINERY
生产线和配套机械

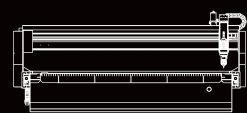

WATER JET

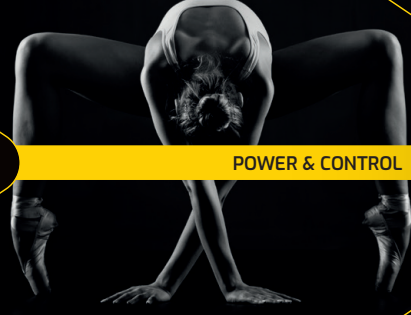

POWER & CONTROL



EXPERIENCE & QUALITY



TECHNOLOGY & INNOVATION



DEVERO GANTRY MANIPULATOR

The DEVERO CNC gantry manipulator with its modular construction can be applied for in-line automatic loading / unloading of machines with belt feeding or table exchanger equipped.

The machine structure is made in electro-welded steel with hot deep galvanizing surface protection, the bridge and the head axis are driven by helical pinions and racks sliding on linear bearings.

To ensure fast and precise positioning also the vertical axes is moving on linear bearings but driven by recirculating ball screw.

Devero is composed by a 370° horizontal rotating head which can be configured for loading or unloading; the rotating unit axes allow the pick-up of randomly positioned cut piece. The tilting sliding PATENTED double vacuum system is suitable for unloading material with polish face on polish face tiles vertical and/or horizontal.

A Vacuum System unit of 100 mc / h and kW. 2.2 is quickly generating the under pressure for fast piece lifting.

The operator interface manages all the machine control functions, alarm, work parameter changes, work phase display, and can be perfectly interfaced with Gmm saws.

Devero is THE HANDLING.

DEVERO 智能卸载机械手

DEVERO数控智能卸载机械手采用模块化结构,可用于配备皮带送料或工作台交换器的机器的在线自动上/下料。

机器结构由电焊钢制成,具有热镀锌表面保护,横梁和机头轴由螺旋小齿轮在线性轴承上滑动并由齿条驱动。

为确保快速和精确定位,Z轴(垂直轴)也在线性轴承上移动并由精密丝杠驱动。

Devero:由一个370度的水平旋转头组成,可配置用于装载或卸载;旋转装置轴允许拾取任意定位的切割工件。倾斜滑动专利双真空系统适用于在垂直和/或水平的抛光表面上卸载抛光面材料。

100mc/h 和 kW2.2 的真空系统装置快速产生真空压力,以便快速提升工件,使得更大的节约时间。

操作界面管理所有机器控制功能、报警、工作参数变化、工作阶段显示,并可与Gmm桥切机完美连接。



POWER & CONTROL



EXPERIENCE & QUALITY



TECHNOLOGY & INNOVATION



TECHNOLOGY & INNOVATION

EXPERIENCE & QUALITY

POWER & CONTROL

Devero

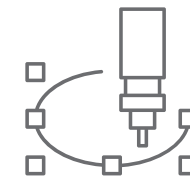
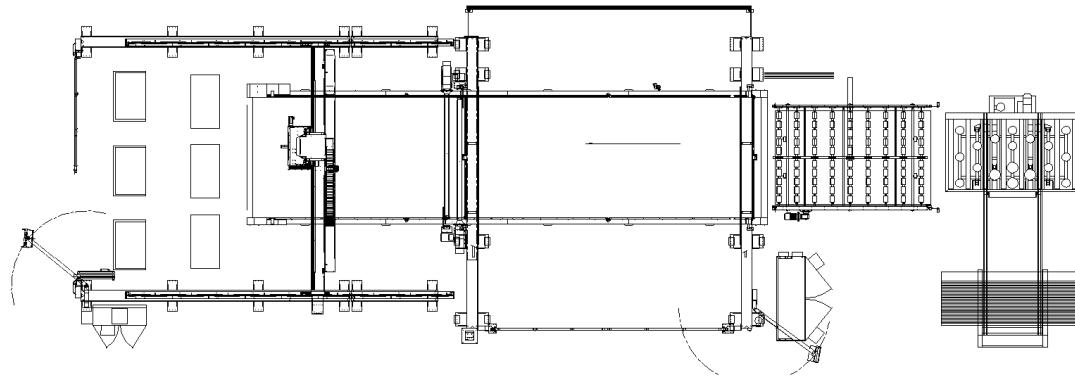

CNC 数控
TECHNOLOGY 技术



TECHNICAL DATA 技术参数

MIN. STRIP WIDTH 最小工作宽度	300 mm
MAX. STRIP LENGTH 最大工作长度	3000 mm
VACUUM PUMP 真空泵	Variable NL/min 选配 (升/分钟)
X AXIS SPEED X轴速度	30 m/min
Y AXIS SPEED Y轴速度	60 m/min
Z AXIS SPEED Z轴速度	12 m/min
WEIGHT 设备重量	2200 Kg
TOTAL POWER INSTALLED 总功率	12 Kw
CAPACITY 装卸重量	Variable Kg 选配 (公斤)
VOLTAGE / FREQUENCY 电压/频率	400/50 V/Hz

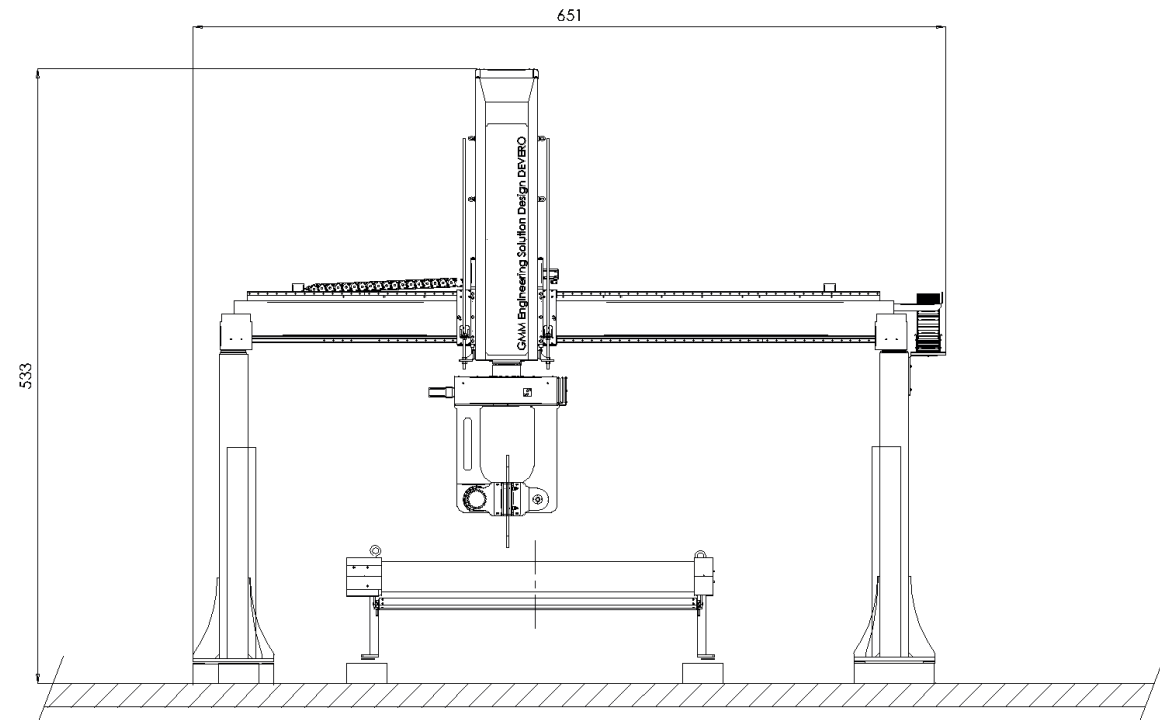

GMM

STONE MACHINERY



GMM S.P.A.
HEADQUARTER 意大利总部
ITALY
www.gmm.it

GMM S.P.A. SCHIO
BUSINESS UNIT
ITALY
www.gmm.it

GMM USA INC.
COMMERCIAL / AFTER SALES UNIT
USA
www.gmm.it

GMM STEINBEARBEITUNGSMASCHINEN GMBH
COMMERCIAL / AFTER SALES UNIT
GERMANY
www.gmm-steinbearbeitung.de

BAVELLONI SPA
HEAD OFFICE / PRODUCTION UNIT
ITALY
www.bavelloni.com

BAVELLONI SPA
TOOLS DIVISION / PRODUCTION UNIT
ITALY
www.bavelloni.com

BAVELLONI AMERICA INC.
COMMERCIAL / AFTER SALES UNIT
USA
www.bavelloni.com

BAVELLONI DO BRASIL
COMERCIO DE MAQUINAS LTDA
COMMERCIAL / AFTER SALES UNIT
BRAZIL
www.bavelloni.com

Z.BAVELLONI MÉXICO S.A. DE C.V.
COMMERCIAL / AFTER SALES UNIT
MEXICO
www.bavelloni.com

TECHNI WATERJET LTD.
MELBOURNE HEAD OFFICE
AUSTRALIA
www.techniwaterjet.com

TECHNI WATERJET LTD.
PRODUCTION UNIT
THAILAND
www.techniwaterjet.com

TECHNI WATERJET LLC
COMMERCIAL / AFTER SALES UNIT
USA
www.techniwaterjet.com

WPA WATERJET
PRODUCTION ACADEMY GMBH
DISTRIBUTOR
GERMANY
www.wpa-gmbh.com

GMM INTERNATIONAL LTD.
凌意国际有限公司
COMMERCIAL / AFTER SALES UNIT
HONG KONG 香港
香港九龙大有街34号新科技广场17楼17室
Tel. +852 2366 6386, Fax:+852 2367 0525
info@gmm.com.hk
www.gmmchina.cn

GMM (QUANZHOU) LTD.
泉州意美美机械有限公司
COMMERCIAL / AFTER SALES UNIT
CHINA 中国
福建南安市海联创业园海西石材城
大理石精品市场二期分区商铺3C-1
邮编:362342
Tel. +86 595 8609 7072, +86 134 3050 4901
info@gmmchina.cn
www.gmmchina.cn

MECTOCE S.R.L.
PRODUCTION UNIT
ITALY
www.mectoce.it

Devero

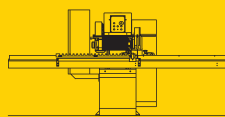

GANTRY MANIPULATOR 智能卸载机械手

Technical data are not binding and may be changed by GMM without prior notice.
技术参数不具有约束力, GMM可能会更改, 恕不另行通知。

IMPORTANT: machines displayed in the present catalogue are without safety barriers in order to ensure the perfect vision of all the details of the machine. All machines will be delivered and installed with safety barriers as per current legislation. The data in the present catalogue may vary without notice due to continuous update of technology.

重要说明: 本说明书为了更清晰地展现设备全貌, 在拍照时撤离了安全保护屏障, 设备在实际交付与安装时都会配备安装保护屏。本产品说明书中的所有参数可能因更新原因而有所不同, 请按照当时咨询时为准。

ISO 9001
BUREAU VERITAS
Certification



Member of:
CONFINDUSTRIA MARMOMACCHINE
www.confimarm.com



ISO 9001:2015 - Certificato N°IT234871